

**Specification:**

**Population range:** 10 persons

**Measures:** 481 x 140 x 130 cm(l,w,h) (standard variant, complete height with aeration scoop)

**Sludge treatment:** stabilizing, volumereduction

**Max. organic loading:** 600g BOD/day

**Max. average daily flow:** 1500l

**Max. blower power consumption:** 55W

**Weight (total/plug&play):** ~360kg

**Total capacity:** 6000l

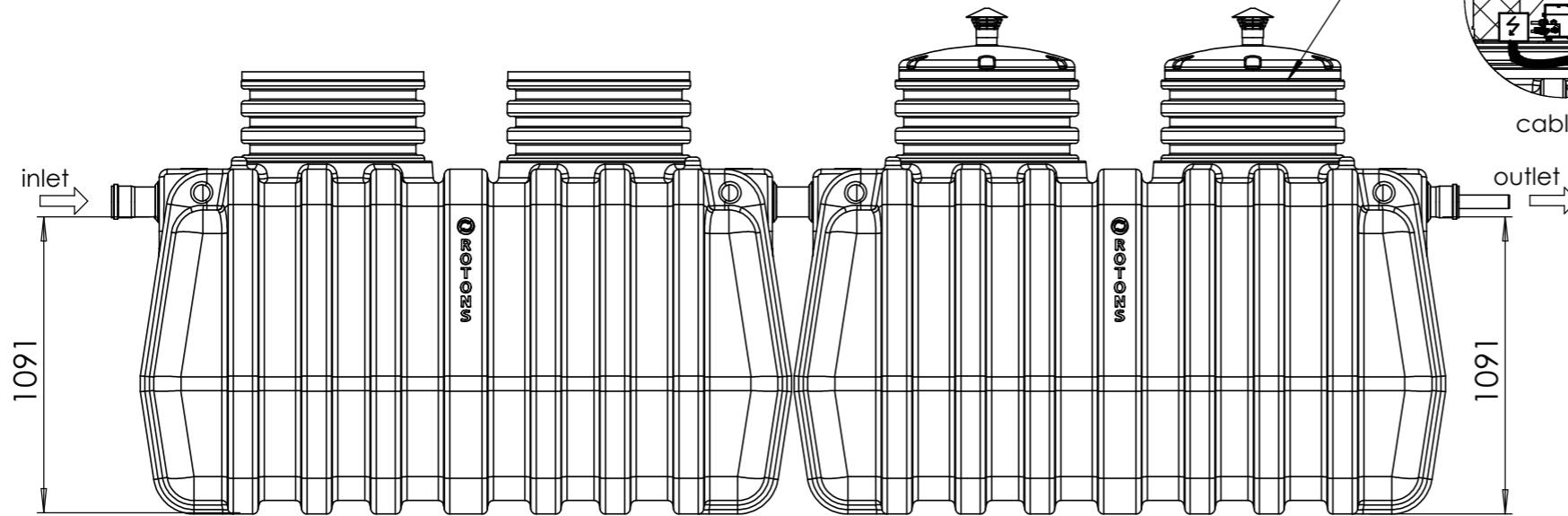

ClearFox - control unit integrated

Power plug-in  
230VAC/3x1,5mm<sup>2</sup>  
+ GFCI - ground vault  
circuit interrupter

The inlet height can be  
extended by replacing a longer  
WAVIN Tegra DN600 pipe  
(as option)

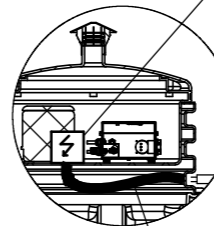

Power plug-in  
230VAC/3x1,5mm<sup>2</sup>  
+ GFCI - ground vault  
circuit interrupter

cable reserve ~1m

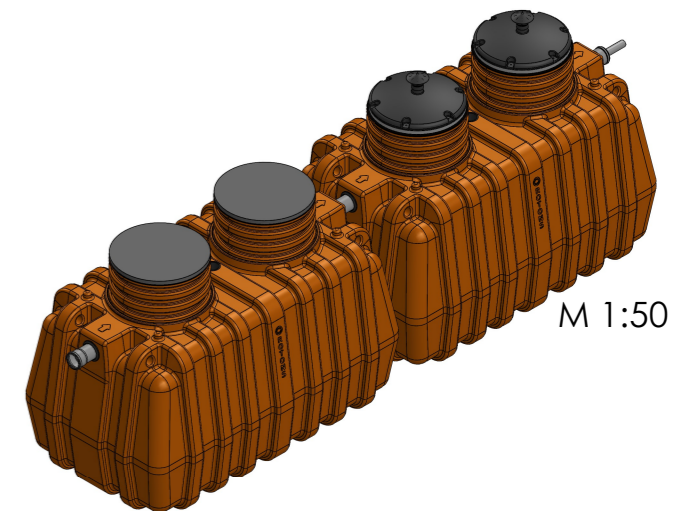
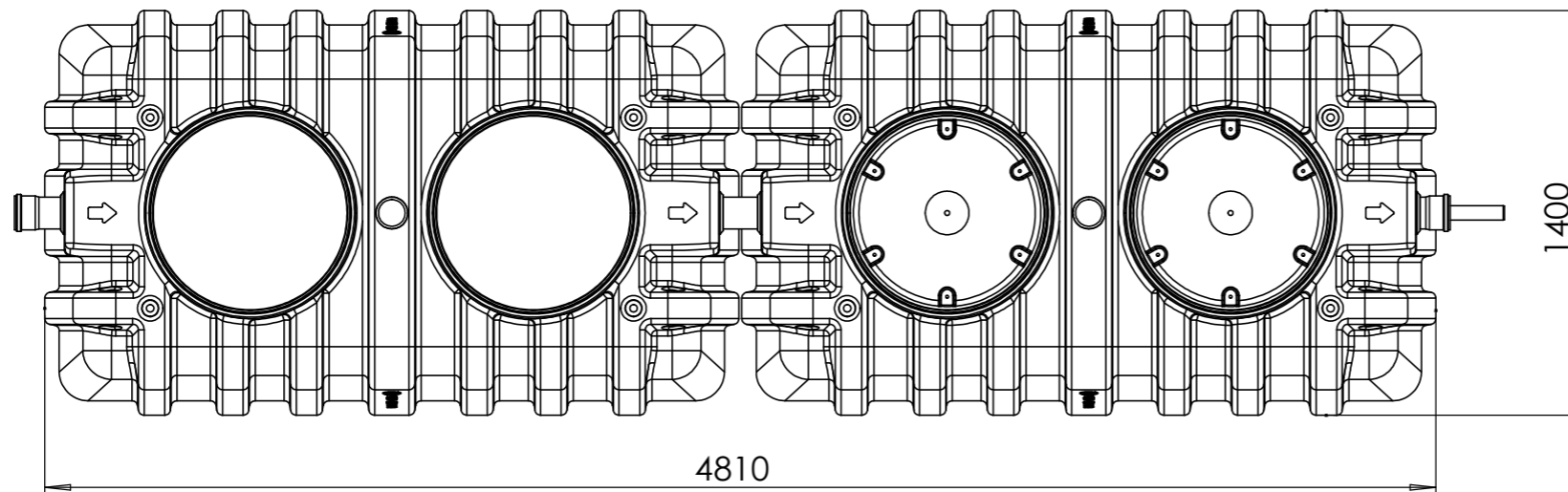
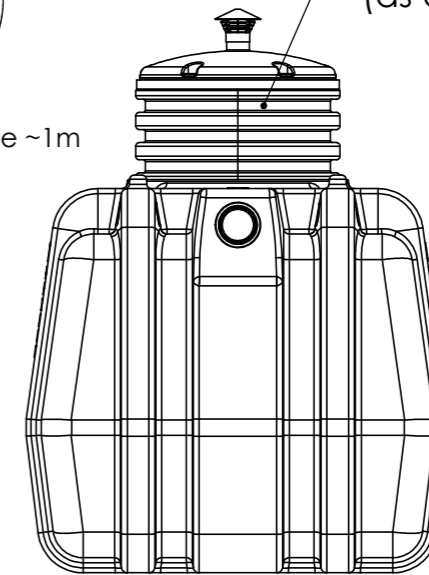

This drawing is our property and may not be reproduced or made accessible to third parties without permission.

					Material	
					Masstab: 1:50	DIN A3
				gez. 17.03.2023	mgr	Artikelnummer:
				gepr.		Benennung
						Q1+ 3000
Rev.	Änderung	Datum	Name			Datei: Rotons_Q1-Tank_6000L