

This drawing is our property and may not be reproduced or made accessible to third parties without permission.

Specification:

Population range: 5 persons

Measures: 240 x 140 x 130 cm(l,w,h) (standard variant, complete height with aeration scoop)

Sludge treatment: stabilizing, volumereduction

Max. organic loading: 300g BOD/day

Max. average daily flow: 750l

Max. blower power consumption: 55W

Weight (total/plug&play): ~180kg

Total capacity: 3000l

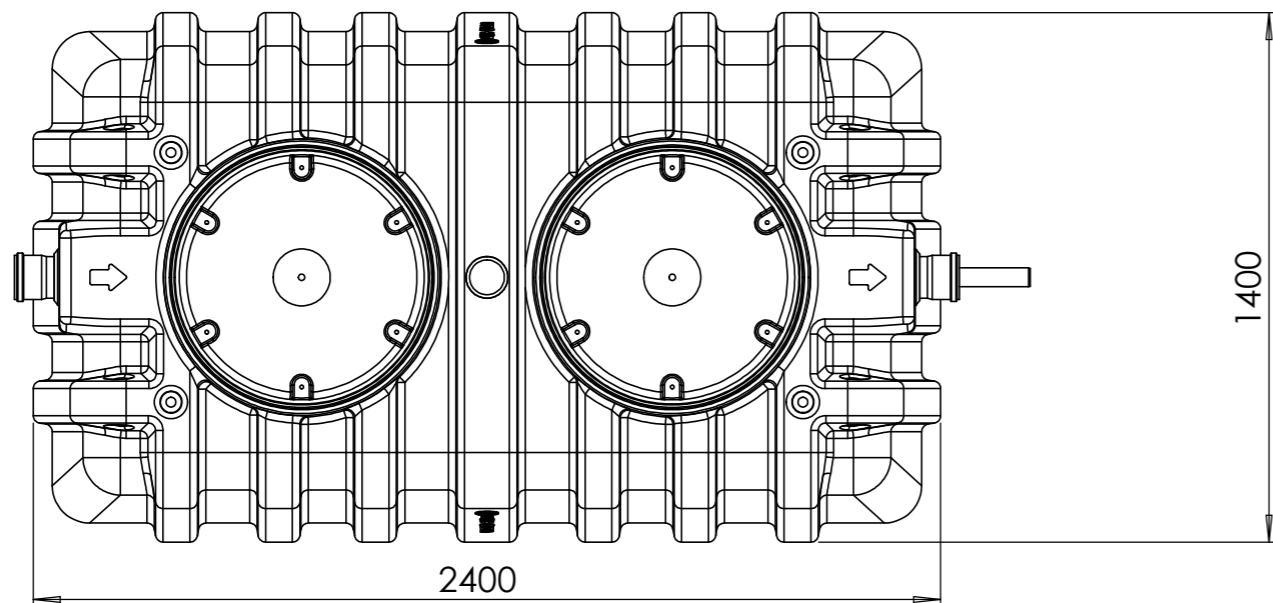
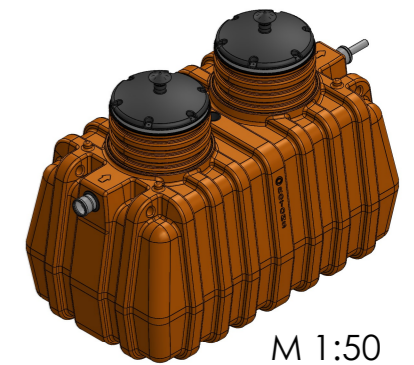
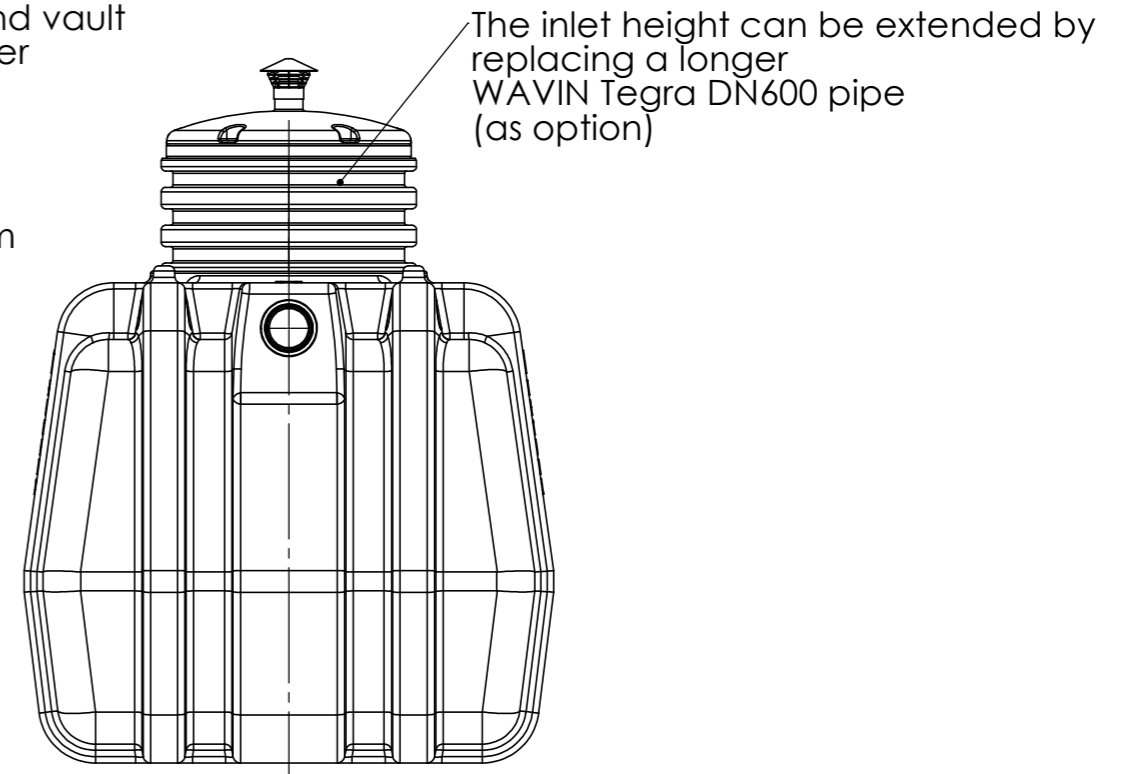
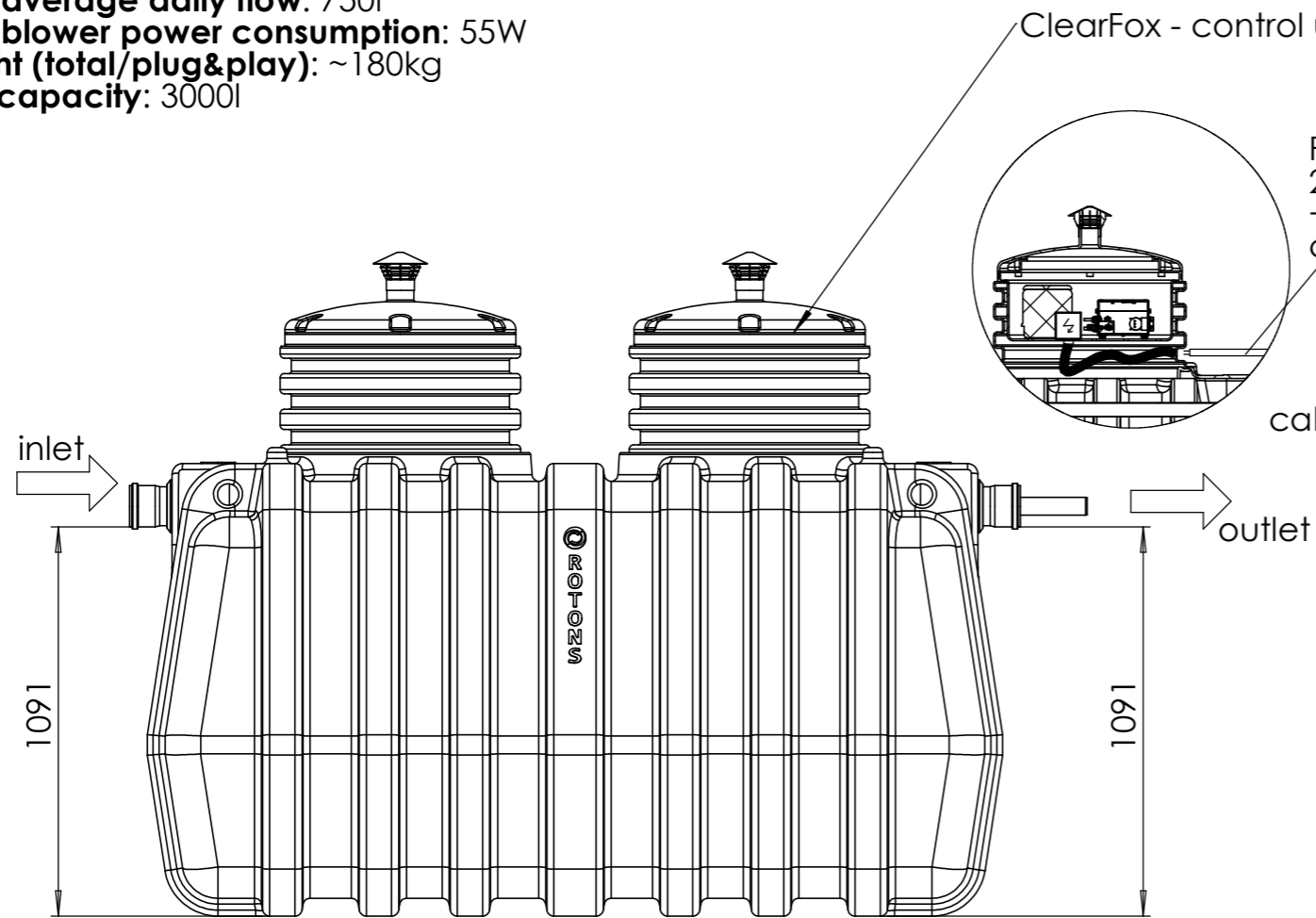

					Material	
				DATUM	NAME	Masstab: 1:20
		gez.	16.03.2023	mgr	Artikelnummer:	
		gepr.			Benennung	
					Q1+ 3000	
Rev.	Änderung				Datum	Name