

**Specification:**

**Population range:** 100 persons  
**Measures:** 980 x 290 x 245 cm(l,w,h)  
**Area Requirement:** 42m<sup>2</sup>  
**Sludge treatment:** Sludgestabilization  
**Max. organic loading:** 6,00 kg/day  
**Max. average daily flow:** 15,00 m<sup>3</sup>/day  
**Max. blower power consumption:** 1,3 KW  
**Weight (total/plug&play):** 17,96 to  
**Total capacity:** 40m<sup>3</sup>

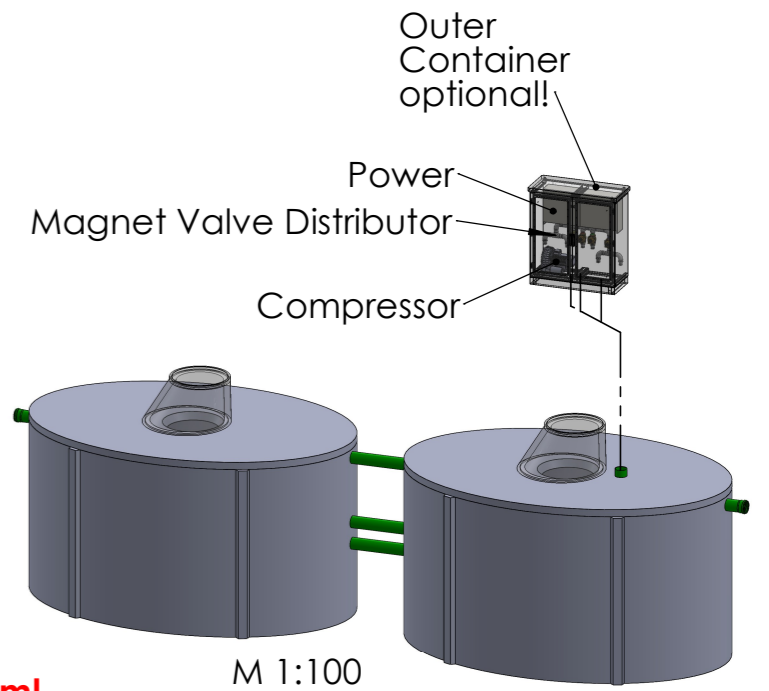
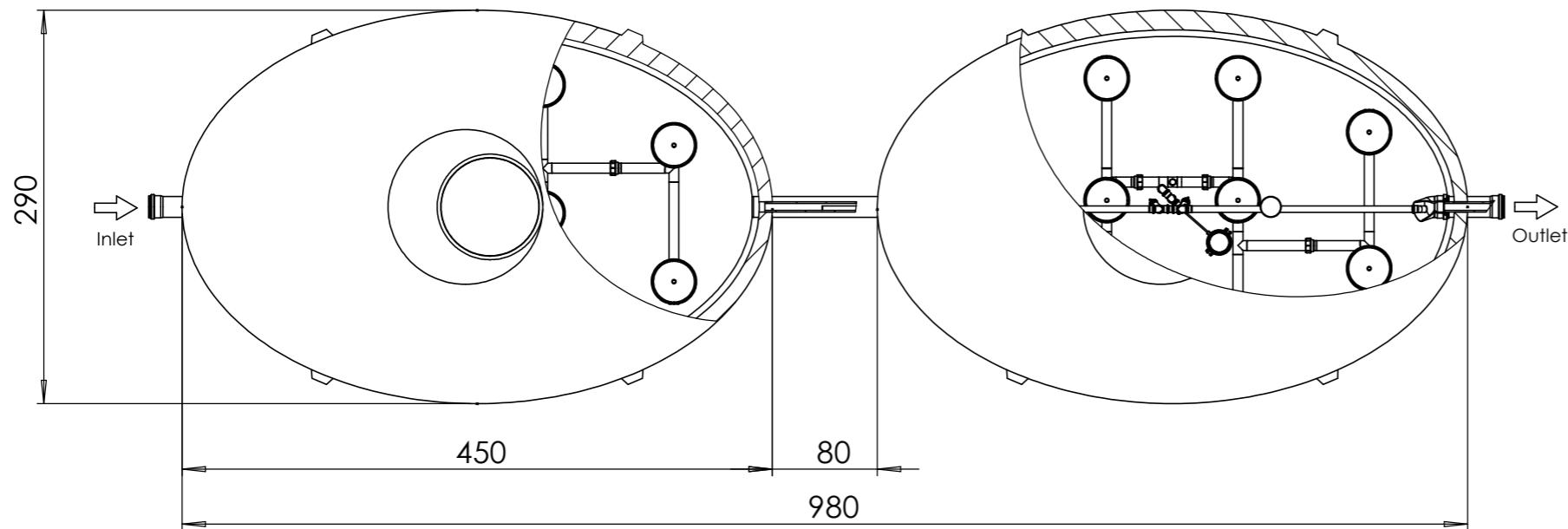
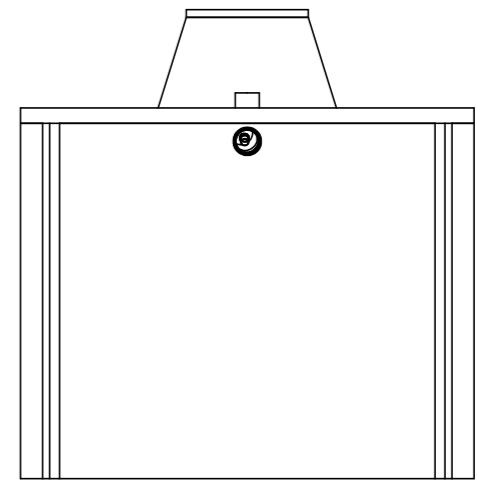
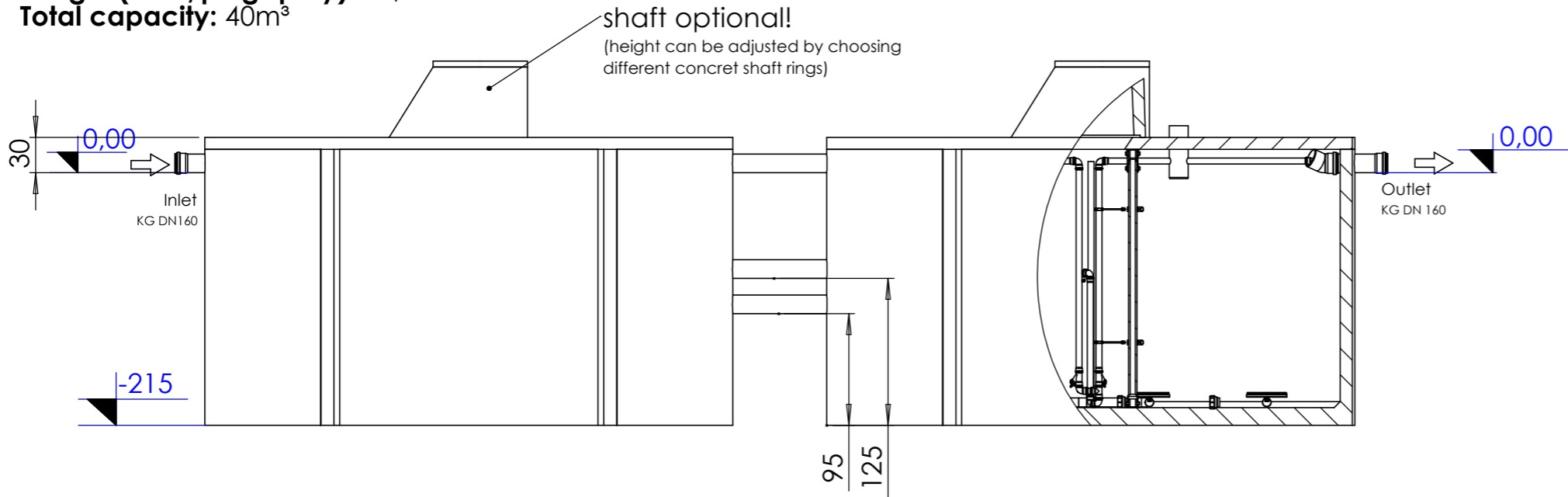

**all measurements in cm!**

					Material
				DATE	NAME
				dra. 25.01.2023	mgr
				chek.	
					Description: QuickONE+ 100 PE One Chamber SBR
Rev.	Change	Date	Name	File: oBeton_QuickONE-WWTP_100pe	Page 1 / 1

This drawing is our property and may not be reproduced or made accessible to third parties without permission.