

Specification:

Population range: 150 persons
Measures: 980 x 620 x 245 cm(l,w,h)
Area Requirement: 63m²
Sludge treatment: Sludgestabilization
Max. organic loading: 9,00 kg/day
Max. average daily flow: 22,50 m³/day
Max. blower power consumption: 1,7 KW
Weight (total/plug&play): 26,94 to
Total capacity: 60m³

shaft optional!
 (height can be adjusted by choosing
 different concret shaft rings)

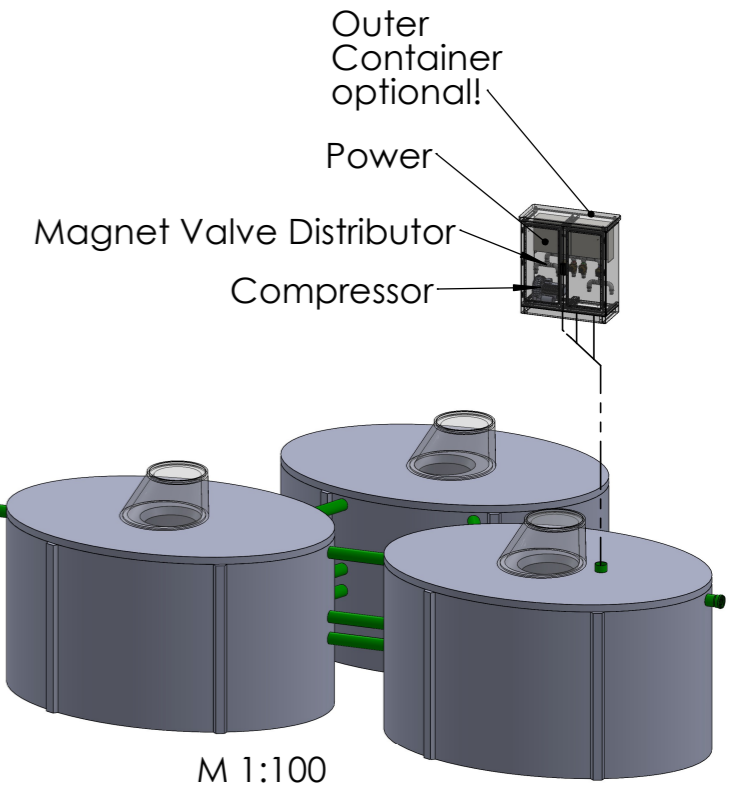
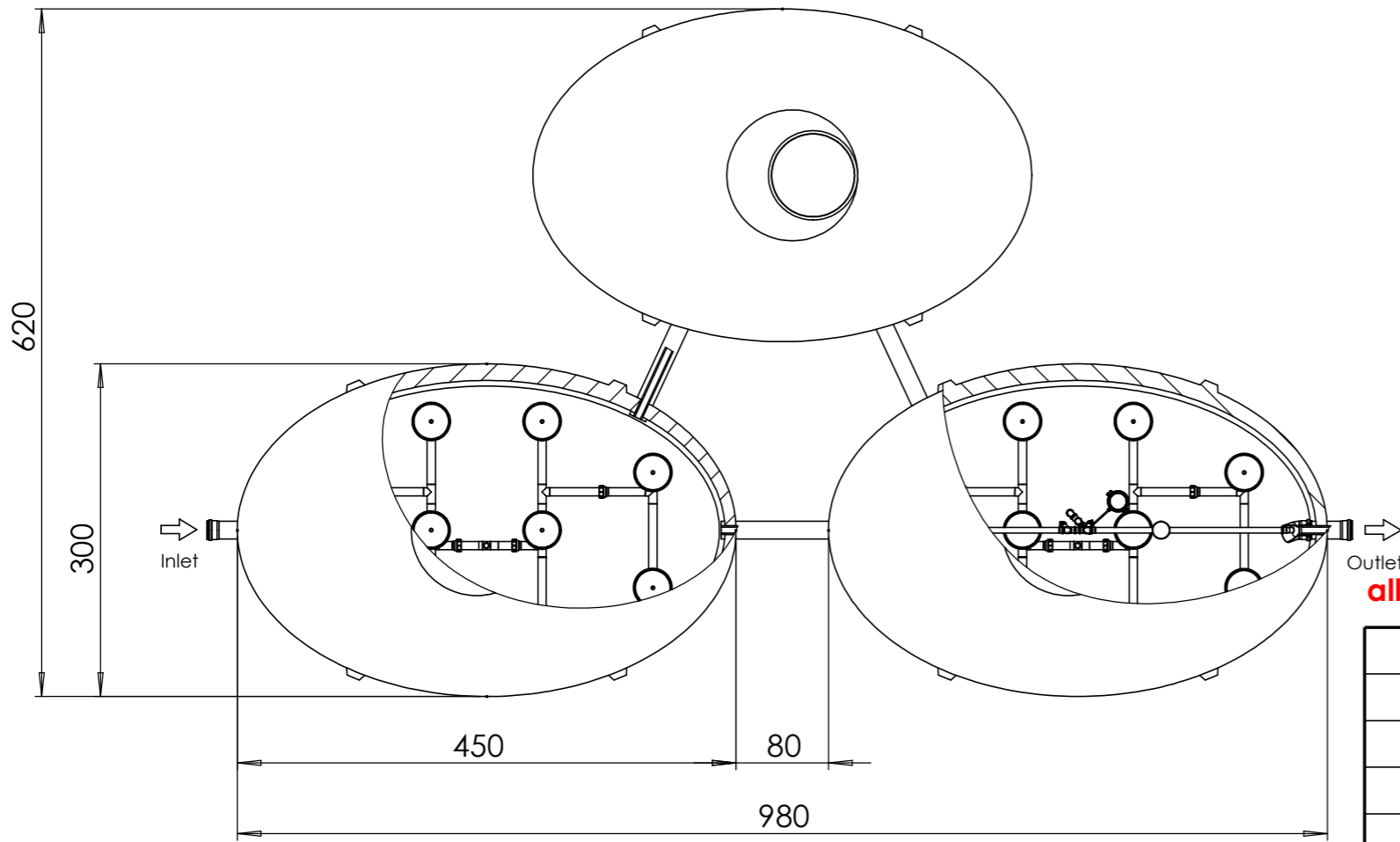
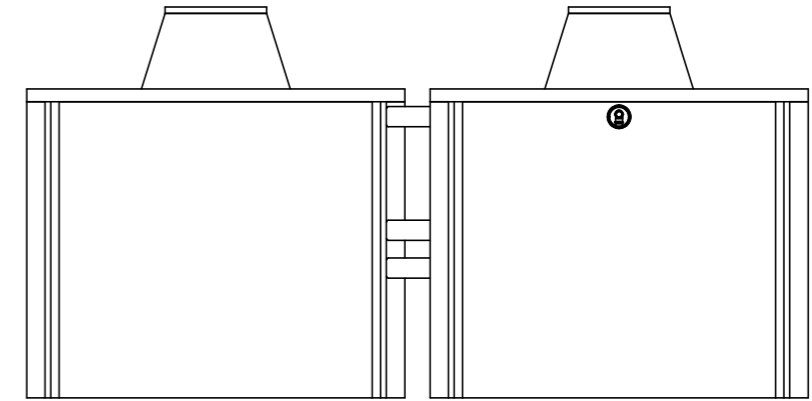
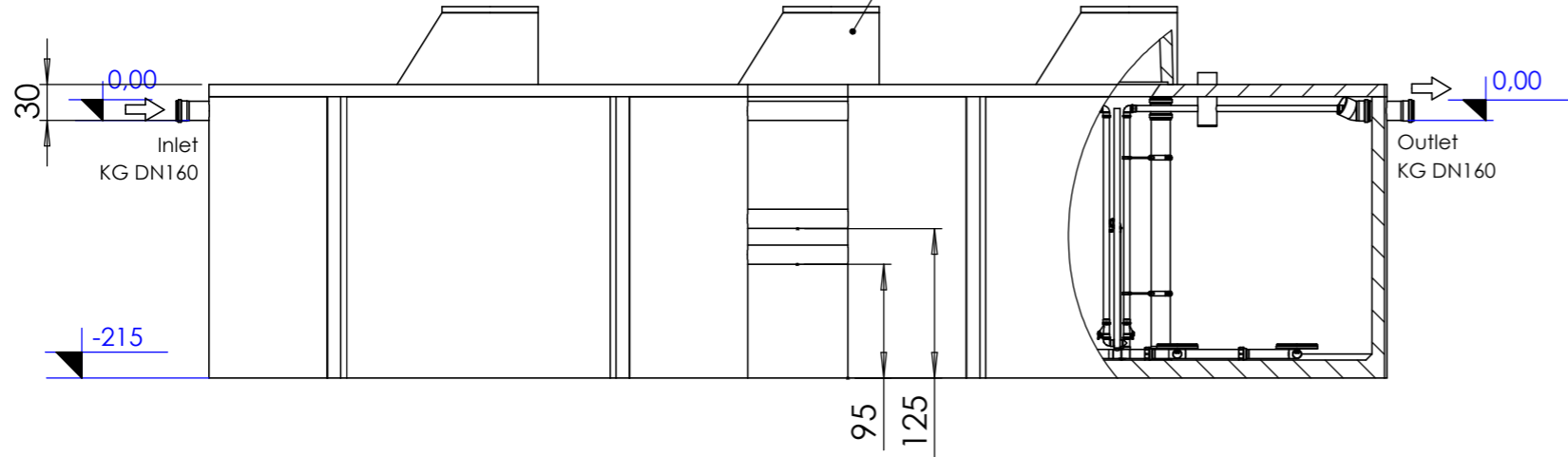

all measurements in cm!

					Material
				DATE	NAME
				dra. 25.01.2023	mgr
				chek.	
				Scale: 1:60	
				DIN A3	
				Part-No.:	
				Description:	
				QuickONE+ 150 PE	
				One Chamber SBR	
Rev.	Change	Date	Name	File: oBeton_QuickONE-WWTP_150pe	Page 1 / 1

This drawing is our property and may not be reproduced or made accessible to third parties without permission.