

Specification:

Population range: 200 persons
Measures: 980 x 680 x 245 cm(l,w,h)
Area Requirement: 84m²
Sludge treatment: Sludgestabilization
Max. organic loading: 12,00 kg/day
Max. average daily flow: 30,00 m³/day
Max. blower power consumption: 2,6 KW
Weight (total/plug&play): 35,92 to
Total capacity: 80m³

shaft optional!
 (height can be adjusted by choosing
 different concret shaft rings)

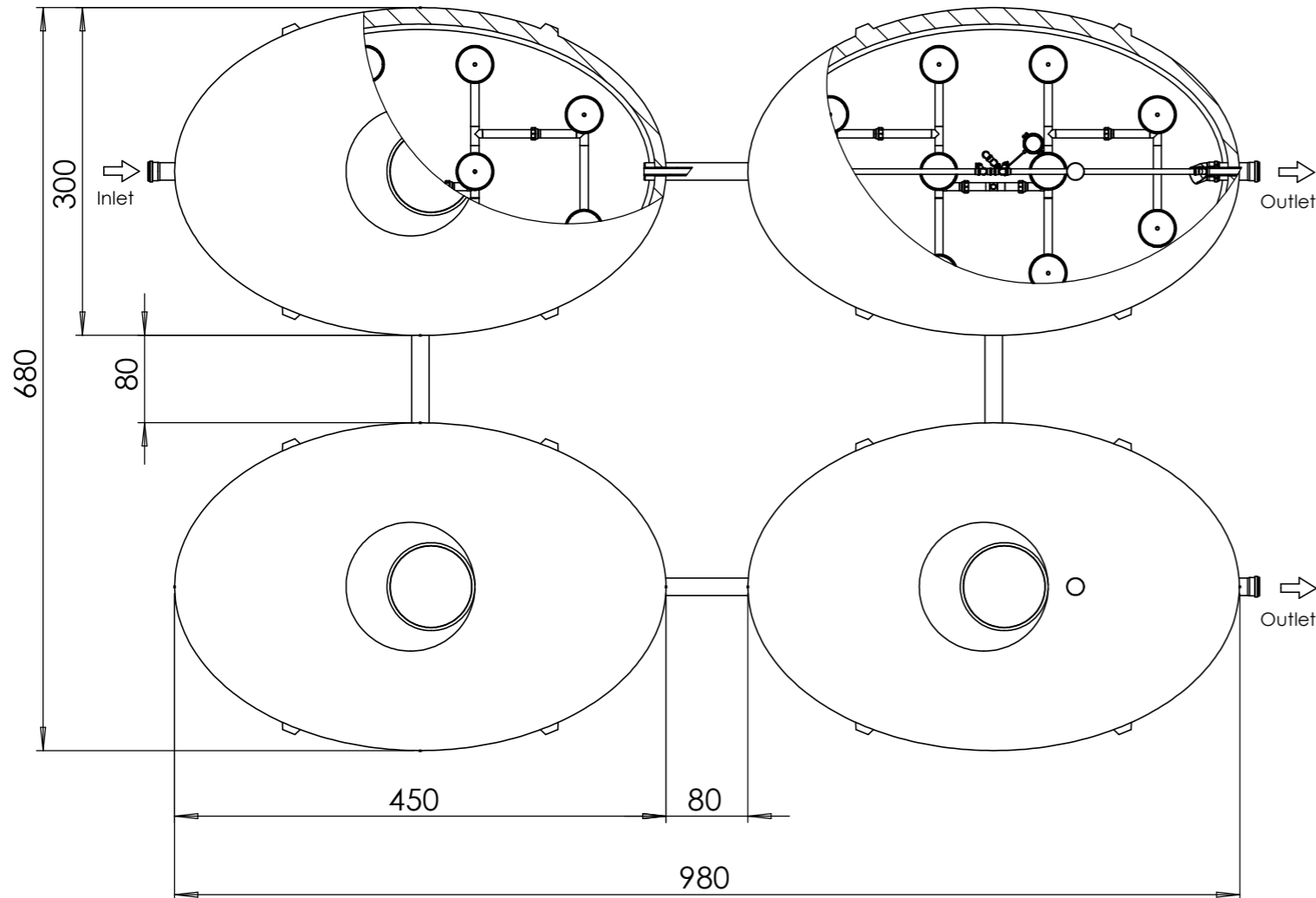
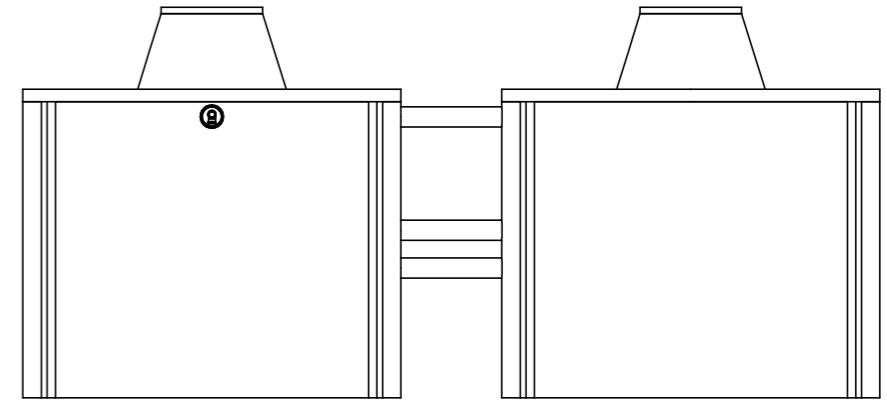
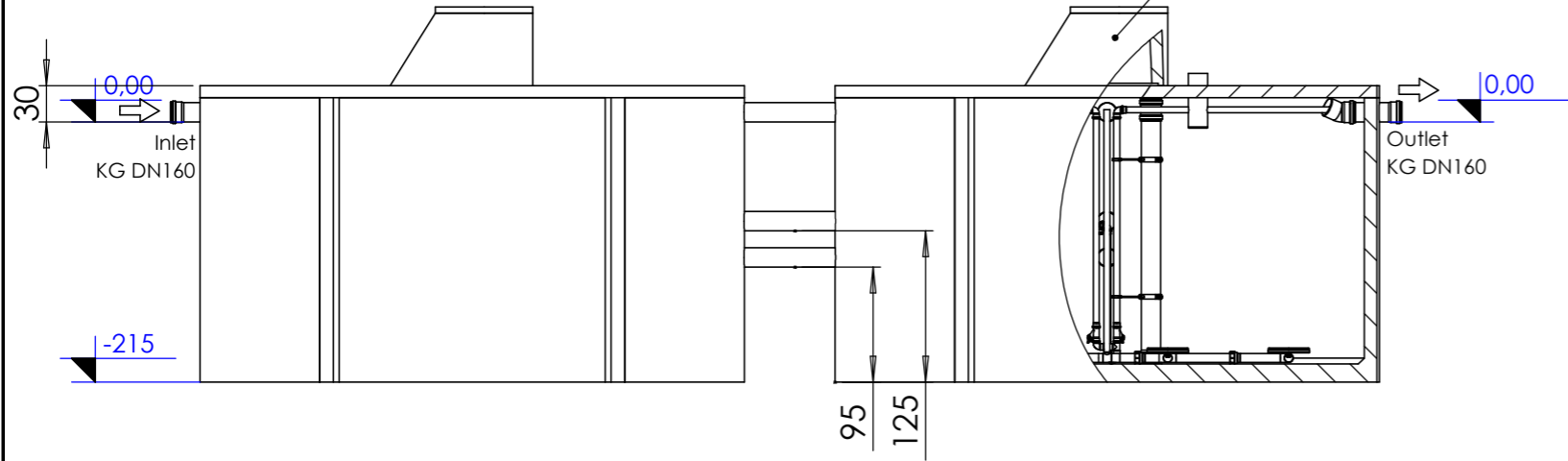

Power
 Magnet Valve Distributor
 Compressor
 Outer Container optional!

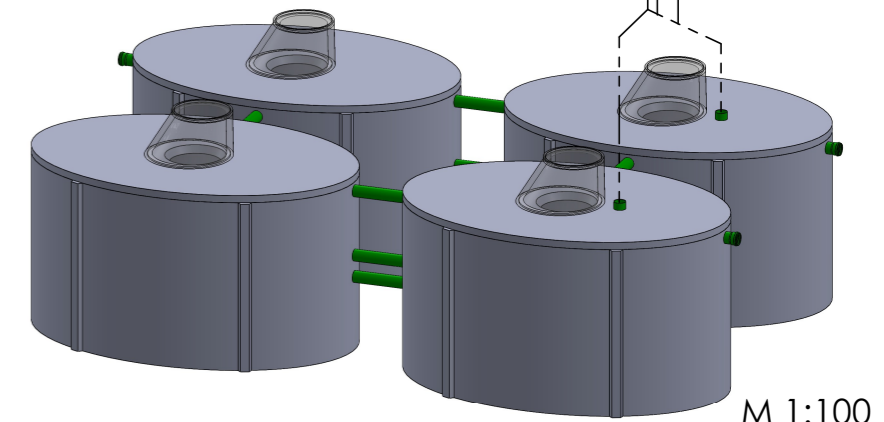

M 1:100

all measurements in cm!

					Material
				DATE	NAME
				dra. 25.01.2023	mgr
				chek.	
				Scale: 1:60	
				DIN A3	
				Part-No.:	
				Description:	
				QuickONE+ 200 PE	
				One Chamber SBR	
Rev.	Change	Date	Name	File: oBeton_QuickONE-WWTP_200pe	Page 1 / 1

This drawing is our property and may not be reproduced or made accessible to third parties without permission.