

This drawing is our property and may not be reproduced or made accessible to third parties without permission.

**Specification:**

**Population range:** 25 persons  
**Measures:** 430 x 240 x 231 cm (l,w,h)  
**Area Requirement:** 18m<sup>2</sup>  
**Sludge treatment:** Sludgestabilization  
**Max. organic loading:** 1,50 kg/day  
**Max. average daily flow:** 3,75 m<sup>3</sup>/day  
**Max. blower power consumption:** 0,3 KW  
**Weight (total/plug&play):** 8,15 to  
**Total capacity:** 15m<sup>3</sup>

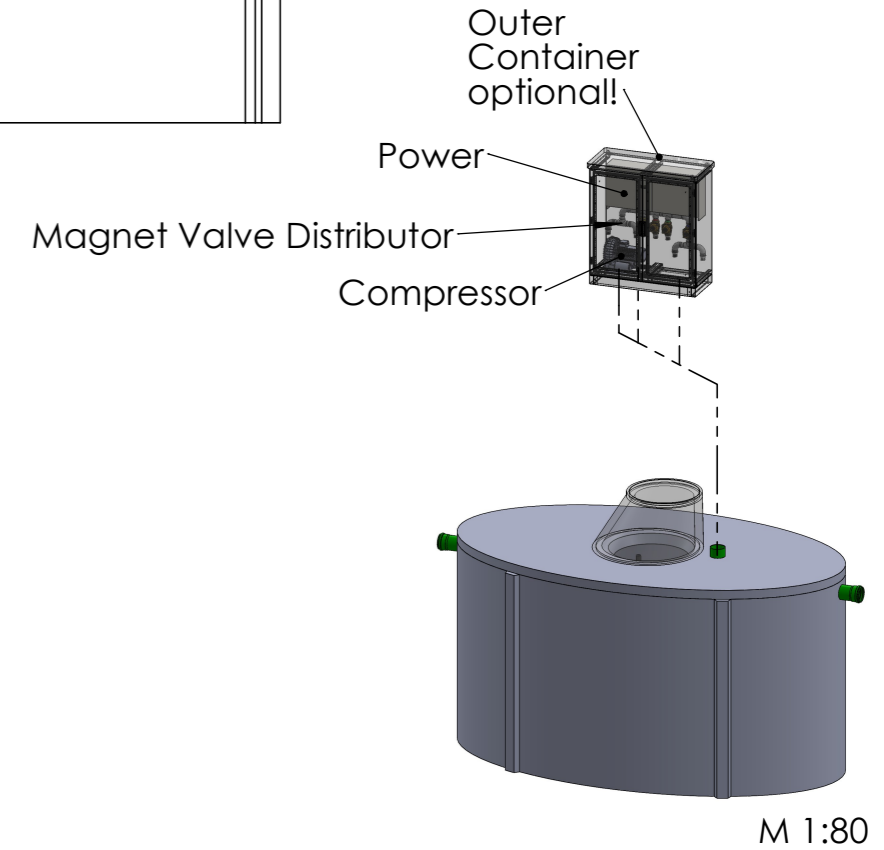
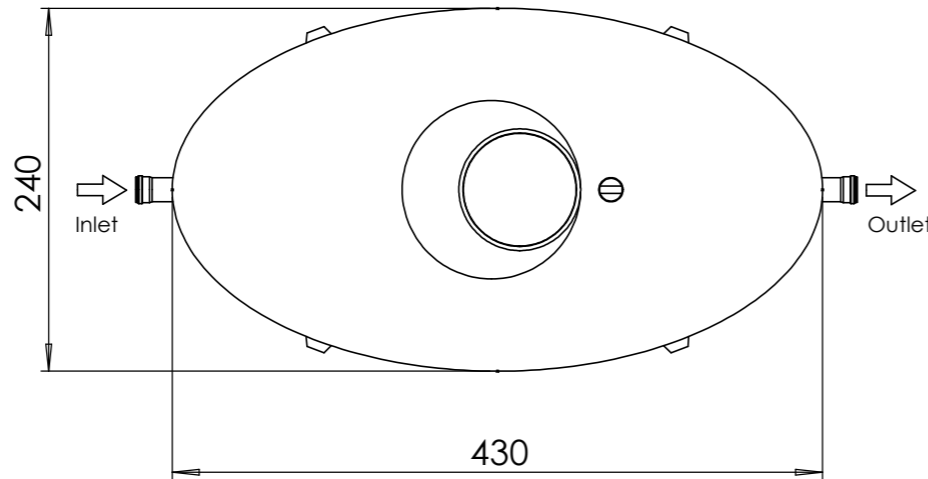
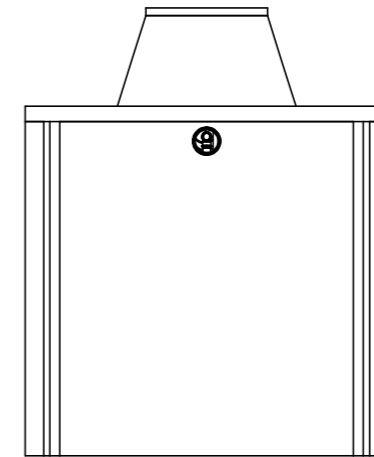
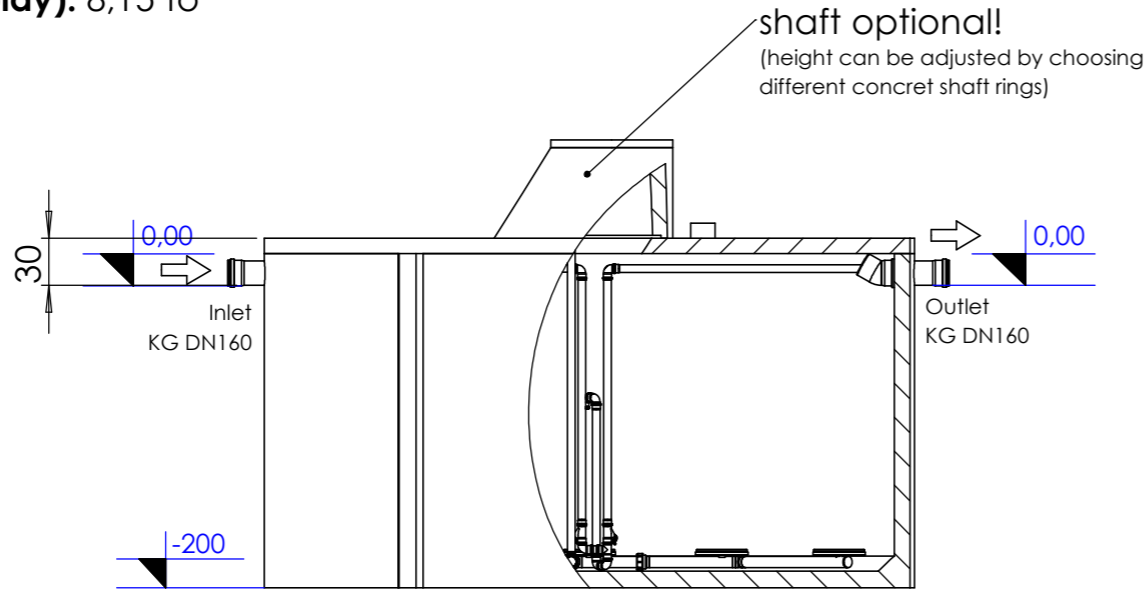

**all measurements in cm!**

					Material
				DATE	NAME
			dra.	25.01.2023	mgr
			chek.		
					Scale: 1:50
					DIN A3
					Part-No.:
					Description: QuickONE+ 25 PE One Chamber SBR
Rev.	Change	Date	Name	File: oBeton_QuickONE-WWTP_25pe	
					Page 1 / 1