

Specification:

Population range: 15 persons

Measures: 722 x 140 x 130 cm(l,w,h) (standard variant, complete height with aeration scoop)

Sludge treatment: stabilizing, volumereduction

Max. organic loading: 900g BOD/day

Max. average daily flow: 2250l

Max. blower power consumption: 150W

Weight (total/plug&play): ~540kg

Total capacity: 9000l

Power plug-in
230VAC/3x1,5mm²
+ GFCI - ground vault
circuit interrupter

ClearFox - control unit integrated

cable reserve ~1m

The inlet height can be
extended by replacing a longer
WAVIN Tegra DN600 pipe
(as option)

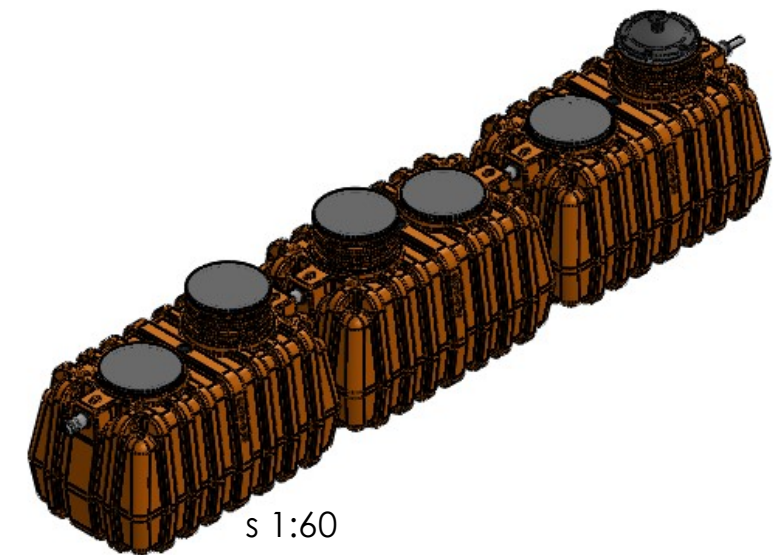
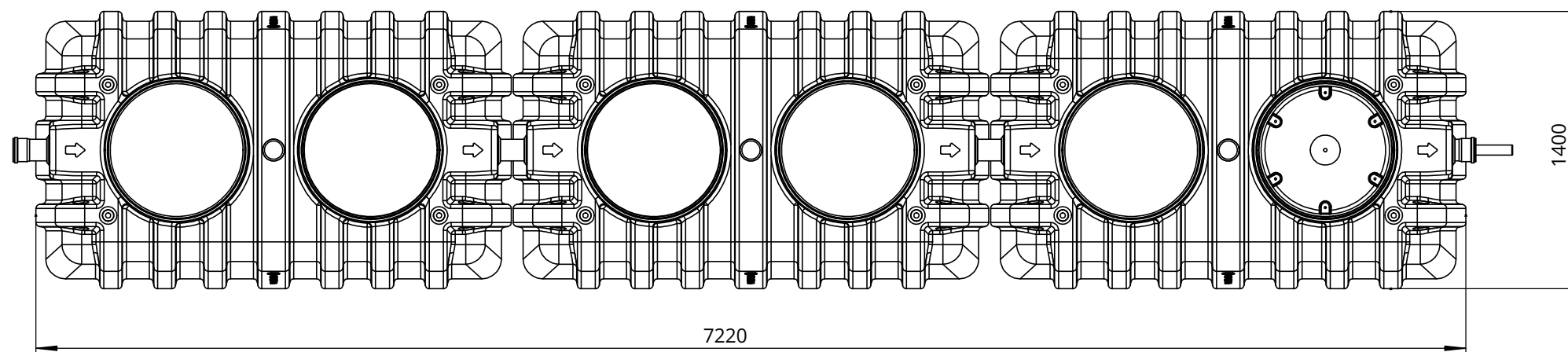
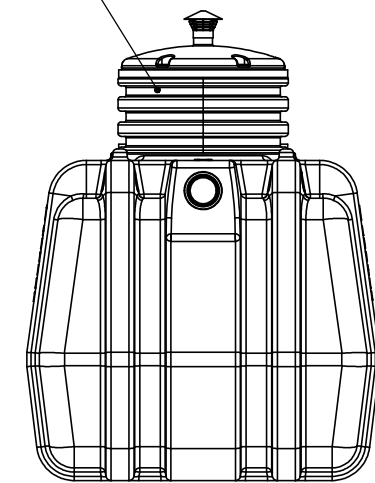
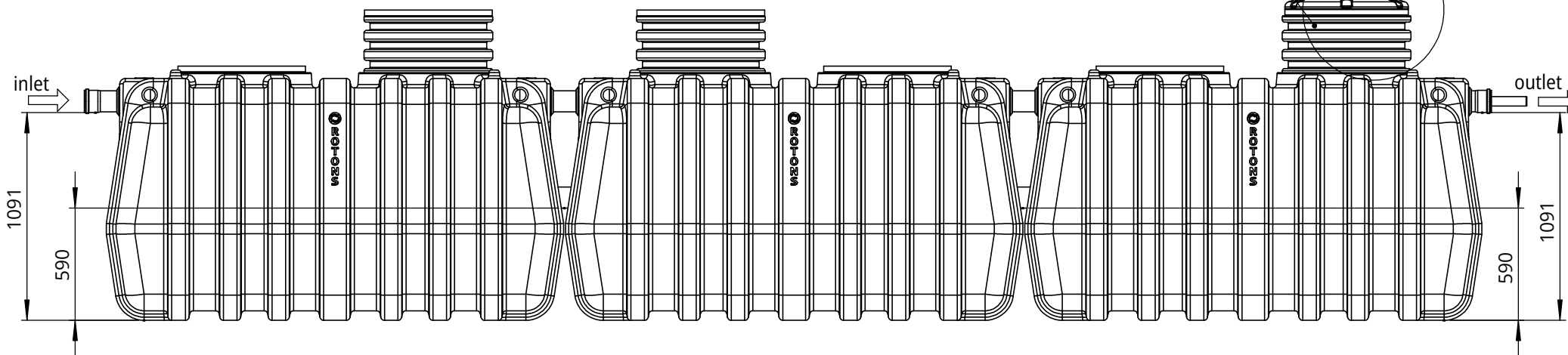

This drawing is our property and may not be reproduced or made accessible to third parties without permission.

				Material	
		DATE	NAME	Scale: 1:30	DIN A3
		dra. 29.06.2023	mgr	Project-No.:	
		chek.		Description:	
				Q1+ 9000	
Rev.	Change	Date	Name	File: Rotons_Q1-Tank_9000L	
				Page 1 / 1	