

This drawing is our property and may not be reproduced or made accessible to third parties without permission.

Specification:

- Population range:** 20 persons
- Measures:** 520 x 280 x 130 cm(l,w,h) (standard variant, complete height with aeration scoop)
- Sludge treatment:** stabilizing, volumereduction
- Max. organic loading:** 1200g BOD/day
- Max. average daily flow:** 3000l
- Max. blower power consumption:** 200W
- Weight (total/plug&play):** ~720kg
- Total capacity:** 12000l

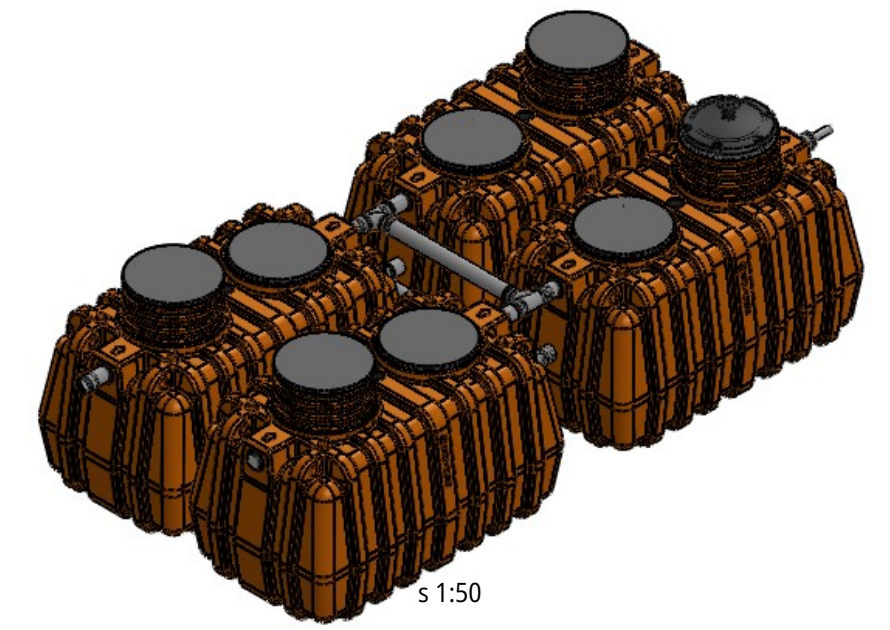
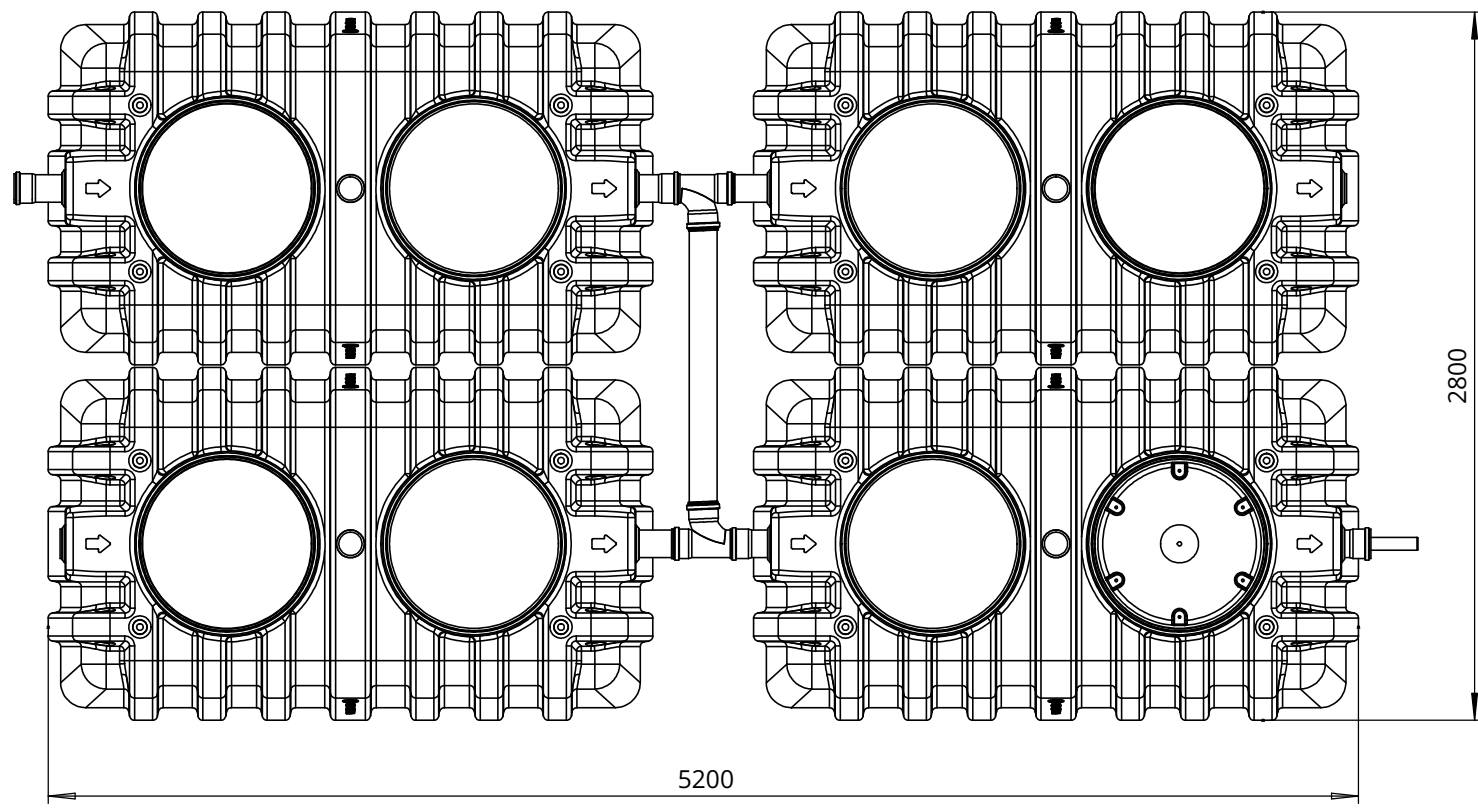
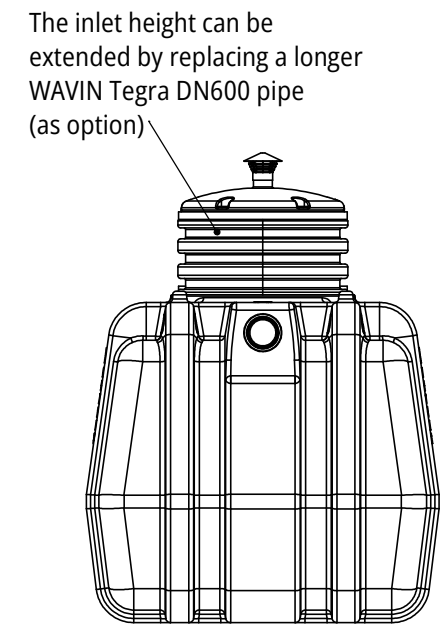
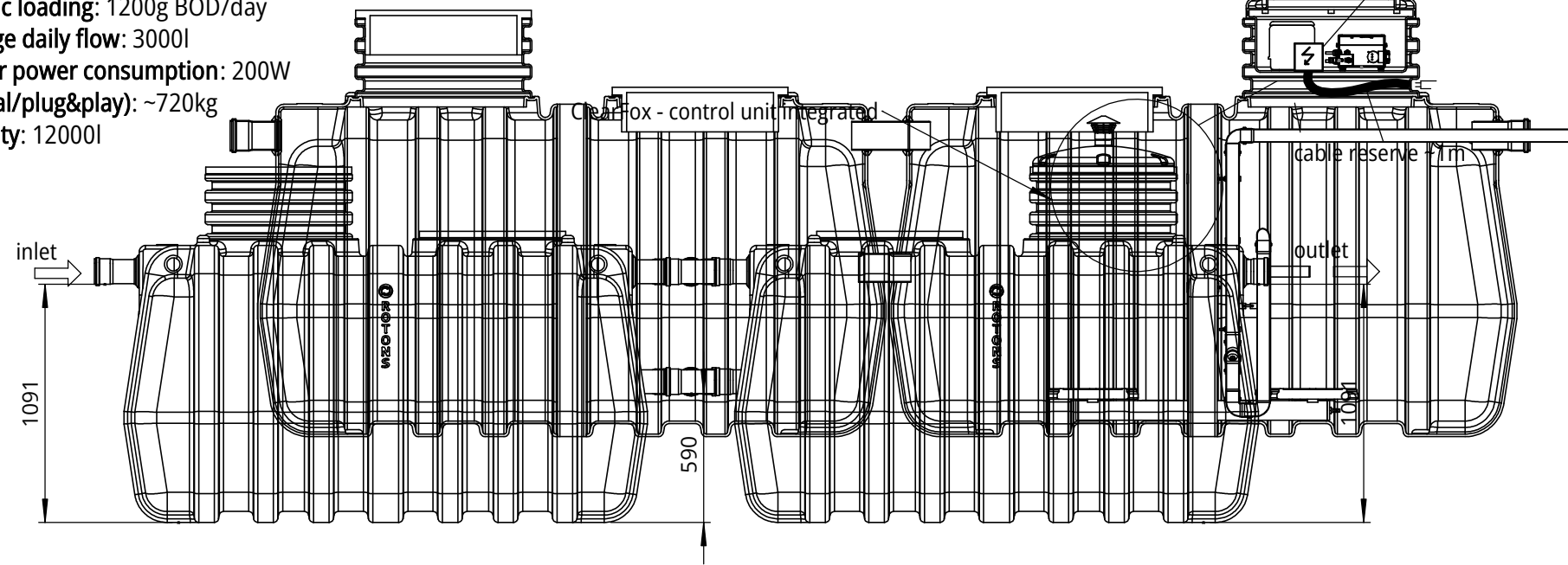

				Material	
		DATE	NAME	Scale: 1:30	DIN A3
		dra. 29.06.2023	mgr	Project-No.:	
		chek.		Description:	
				Q1+ 12000	
Rev.	Change	Date	Name	File: Rotons_Q1-Tank_9000L	Page 1 / 1